



The Iowa Automotive Recyclers NEWS

DECEMBER 2011/JANUARY 2012

Sandhill Auto Salvage Donates Car to Prom Winner

Mike and Mitzi Waterbury of Sandhill Auto Salvage in Tama, Iowa donated the fully-loaded 2005 Chevy Malibu that had some damage to the left rear quarter panel to the giveaway at the local high school "After Prom" event. For the second year, a group of local business people have donated a vehicle to be awarded as one of the prizes

at the event. Sandhill customers, Kupka Towing and Auto Body and Duane Cline Body Shop repaired the vehicle.

Mechanical inspection and an oil change were provided by D's Auto and tire rotation was donated by Bear's OK Tire. As the final touch, S&S Car Wash detailed the car. Tama Police provided a free vehicle inspection so it could be registered and licensed.

After Prom is a tradition stay-safe event following the senior high school prom which historical has been plagued with some tragic accidents. The After Prom event encourages students to stay safe and sober at an



organized function and to stay off the highways. The annual event provides a variety of activities for Prom-goers in a supervised environment and is organized by parents of South Tama High School students.

Mitzi Waterbury said "They had such a great experience with the project in the first year that they did not

hesitate to donate again this year." Needless to say the high school seniors who have won the giveaways were very excited. Dalyn Waldo, the South Tama High School senior who won a car at the After Prom event in April 2010, says her new car "is really great and drives really great." "It's so much better than my old car," she said. Waldo is attending the University of Northern Iowa, Cedar Falls, and majors in English Education.

Sandhill Auto Salvage is indeed a salvage facility with heart and exemplifies the community involvement and commitment of auto recycling.



CrashLink™

Integrated Crash Guide

▶ OE interchange

▶ Fast F-key lookup

▶ OE Diagrams

▶ Automatic updates

▶ Pricing calculator

helps value assemblies, interchange and non-interchange parts for collision repair pricing.

859-344-1925

<http://products.Car-Part.com>



Car-Part.com

What's new at Car-Part.com?



Car-Part Pro!™

- Increase sales to professional repairers
- Provide delivery times to shops based on your delivery zone and production process.
- Broker parts to shops on Car-Part.com
- Boost extended warranty sales with price built in
- Promote your quality by listing certifications and national, local and private memberships.

Car-Part Pro is part of the Gold Package. Call and we'll get you configured.
<http://products.Car-Part.com> • 859-344-1925



The Iowa Recycler is published six times per year for the Iowa Automotive Recyclers. None of the material in this publication necessarily reflects the opinion of IAR, it's officers, directors, staff, members or it's Publisher. Statements of fact and opinion are the responsibility of the author alone.

Articles and letters suitable for publication will be published in the next scheduled newsletter as space permits. Material should be sent to the Executive Director, Sue Schauls. Articles may be edited for length.

Throughout this issue, trademarked names are used. Rather than place a trademark symbol in every occurrence of a trademarked name, we state we are using the names only in an editorial fashion, and to the benefit of the trademark owner, with no intention of infringement of the trademark. Mention of trade names, commercial products, or techniques does not constitute endorsement or recommendation for use.

Advertising rates: Contact Publisher for Advertising.

Executive Director

Sue Schauls, Executive Director

2214 Regal Avenue
Waterloo, Iowa 50702
Phone: 319-233-7970
Fax 319-233-7970
Cell: 319-290-7843
Email: Schauls3@mchsi.com

Lobbyist

James Piazza, Jr., Lobbyist

Attorney at Law
2415 Ingersoll Avenue
Des Moines, IA 50312
Phone: 515-243-2080
Fax: 515-288-9477
Email: JamesPiazzaJr@hotmail.com

Newsletter Publisher

IAR retains the services of
R. J. McClellan Inc.
Call any staff member,
Monday through Friday, 9 a.m. – 4 p.m.
Phone 651-458-0089 • Toll Free 877-525-4589
Fax 651-458-012
E-mail: newsletters@rjmc.com
Ron McClellan
President, Advertising Sales
Sheila Cain
Vice President, Creative Director
Ryan McClellan
Layout and Design

IAR's 2012 Board of Directors

Brent Nugent, President

Nugent Auto Sales, Inc.
115 South Clark
Maquoketa, IA 52060
Phone: 563-652-2231
Email: brent@nugentautos.com

Tracy Hurst, Vice President

Hurst Salvage
4019 4th Ave. West
Spencer, IA 51301
Phone: 712-262-3011
Email: hsalvage@ncn.net

Jeff Smid, Secretary

Jeff Smid Auto, Inc.
10330 Highway 65
Iowa Falls, IA 50126
Phone: 641-648-2375
Email: JeffSmid@yahoo.com

Joel McCaw, Treasurer

Ace Auto Recyclers
2752 S Riverside Drive
Iowa City, IA 52246
Phone: 319-338-7828
Fax: 319-337-3234
Email: AceAuto@lowadsl.net

Mike Waterbury, Immediate Past President

Sandhill Auto Salvage
1981 Hwy. E64
Tama, IA 52339
Phone: 641-484-2057
Email: parts@sandhillautosalvage.com

Jodi Kunde, Special Funds Manager

North End Auto Wrecking
55 W. 32nd Street
Dubuque, IA 52001
Phone: 563-556-0044
Toll Free: 800-545-8885
Fax: 563-556-5097
Email: NorthendWrecking@aol.com

Tom Quandt

Quandt Auto Salvage
18829 Kittyhawk Ave
Carroll, IA 51401
Email: QASinc@qwestoffice.net

Mike Davidson

Don's Auto & Truck Salvage
1500 SE 30th Street
Des Moines, IA 50317
Phone: 515-262-8283
Email: Mike@DonsAutoAndTruckSalvage.com

Brad Osborn

Waterloo Auto Parts
1501 Grandview Ave
Waterloo, IA 50703
Phone: 319-234-5207
Email: Brad@WaterlooAutoParts.com

Eric Piper

Spilman Auto Parts, Inc.
20311 Old Highway 2 P.O. Box 31
Bloomfield, IA 52537
Phone: 641-664-2463
Email: eric@spilmanauto.com

Andy Wilken

Wilken & Sons, Inc.
1157 - 275th Street
Nashua, IA 50658
Phone: 641-435-4077
Email: wilkenauto@yahoo.com

Scott Frank, Legislative Liason

Sam's Riverside Auto & Truck Parts
3900 Vandalia Road
Des Moines, IA 50317
Phone: 515-265-8792
Email: Scott@SamsRiverside.com

Tim Smith

Smith Auto Parts & Sales, Inc.
3205 West Grimes
Fairfield, IA 52556
Phone: 641-472-4200
Email: smithparts@iowatelecom.net

Tom Snyder

Snyder's Auto Body
1526 E. Washington Street
Clarinda, IA 51632
Phone: 712-542-5316
Email: snyder@iowatelecom.net

Mike Swift

Trail's End Auto & Truck Salvage
1600 N.E. 44th Avenue
Des Moines, IA 50313
Phone: 515-265-5696
Email: mike@trailsendauto.com

David Hesmer

Action Auto Parts
100 South 18th Avenue
Marshalltown, IA 50158
Email: david@action-auto-parts.com

Visit our website
www.iowaautorecyclers.com

IOWA AUTOMOTIVE RECYCLERS

Teleconference IAR Board Meeting Tuesday, August 23, 2011 5:30 P.M.

President Brent Nugent called the meeting to order at 5:47 p.m. Members present were: Brent Nugent, Sue Schauls, Tracy Hurst, Mike Swift, Scott Frank, Jodi Kunde, Mike Waterbury, David Hesmer, Tom Snyder, Mike Davidson, Tom Quandt, Joel McCaw, and Jeff Smid.

MINUTES: Tracy made a motion to accept the minutes from the July 19th meeting as written with a second from Jodi; motion carried.

TREASURER'S COMMENTS: Joel said he wrote the five \$1000 scholarship checks and just mailed those to Jodi. There was some discussion of the CMARC income and expenses for the upcoming convention in September.

SCHOLARSHIP: As reported above, Jodi will be mailing the scholarship checks as soon as she receives those from Joel. Sue said she will update the website with the scholarship information and will also see about putting articles in the recipients' local newspapers.

PAC: Jodi reported on the balance of the fund. Sue said she will keep in touch with Jim Piazza as far as his priority list of donations the board should make.

LEGISLATIVE: Mike Swift talked about a few of the things going on with the legislative committee. Sue said she has met with Jeff Danielson, a member of the Transportation Committee, and extended an invitation to him for a coffee and/or yard tours. There is a Danielson event scheduled for September 26th in Des Moines.

SUMMER OUTING 2012: Sue and Brad have been working on getting the venue and dates set and will have more on this in the near future. Tentative date for 2012 Summer Outing is June 8-9, 2012 in Waterloo, Iowa.

CMARC: Sue said there are 21 vendors scheduled to attend CMARC at this time. Once again,

she encouraged all board members to get their registrations in as soon as possible for the September 23-24th convention. She will be sending out an announcement to all the IAR members about the convention along with an electronic registration form.

VENDOR CONFERENCE CALL: The vendors on the July 27th call were all very pleased with the Summer Outing in June. Sue said we need to keep adding vendors to the membership and make sure we keep in contact with them.

NEWSLETTER: Sue asked for a board member to proofread the newsletter, and Scott volunteered to do that. There was some discussion on member profiles and some suggestions for those.

MEMBERSHIP: Sue brought up the possibility of purchasing a mailing list, which would have information on all body shops and auto repair shops in Iowa.

WHO'S WHO: Sue reported on the WHO'S WHO and said it will be out soon. If she needs further help, she will contact board members.

OTHER BUSINESS: Sue asked about some of the inactive committees and what the board would like to do about those. Jodi will email the board members the most recent list of committees and members and it will be discussed at a later date.

Mike W. talked about the DOT making inspections of the use of off-road fuel and the fines associated with this.

The next meeting will be a teleconference call soon after CMARC with a face-to-face meeting after that.

There was a motion by David to adjourn with a second from Scott. The meeting was adjourned at 7:13 p.m.

Respectfully submitted,
Jeff Smid, Secretary

President's Pitch

By Brent Nugent,, IAR President



Hello Fellow Recyclers!

As I write this I look out the window and see winter fast approaching. As industry leaders we will have many customers that will be coming into our establishments in need of good, clean reliable used parts. They are relying on all of us...SALVAGE FACILITIES to have that part for them. Most of us have a motto that if we don't have it, we can get it! So let's all make a commitment to keep this industry strong and get that part to & from one another.

I want to take a moment and tell you that the Central Midwest Auto Recyclers Convention was held in Springfield, Illinois on September 23-24, 2011. CMARC was a

success for those of us that attended. The classes were well worth the trip to Springfield. They gave us a lot of information in a short amount of time. The Automotive Recyclers Association President, Doug Reinert, offered opening remarks. Doug highlighted the many successes that the automotive recycling industry has achieved in recent years and the pivotal role we play in supplying used auto parts to the market during these trying economic times. He reminded us that the days of the "junkyard" are gone and that we can and do exemplify the modern **Used Parts Store and Salvage Facility** using high tech inventory computer systems to provide quality guaranteed parts to the consumer

You pull your own parts and save money!



- ★ Self Serve Auto Parts
- ★ Highest Level of Customer Care & Convenience
- ★ All vehicles are on stands in our flat, debris free yard
- ★ Inventory rotated regularly to ensure a fresh supply of parts

***Open 7 days
a week!
8AM - 5PM***

***Call us at
515.265-7509***

WWW.WRENCH-N-GO.COM

4100 Vandalia Road • Des Moines, IA 50317

The Iowa Automotive Recyclers News

and to the many automotive repair service providers on which consumers rely.

The CMARC conference hosted many quality speakers and vendors at the two day trade show and on the agenda. At the Lincoln Presidential Library & Museum reception attendees enjoyed networking while touring

the museum exhibits **thanks to the event sponsors; Car-Part.com, URG and Hollander, a Solera Co.** The auction was large contributor to the financial success of the convention. Thank you to the sponsors.

I hear the golf outing hosted was

good fun too. The **CMARC Golf Outing Sponsor, Legend Smelting & Recycling** was also the big winner of the day and generously donated the prize to the convention at the auction. Thanks Legend.

Thank you to the 2011 CMARC Lunch and Show sponsors RJ McClellan, Insurance Auto Auctions, LSB Insurance, Market Financial Group, LKQ Corporation, Salvage Direct, Miller Compressing Company, and Auto Data Direct.

Thank you to our Executive Director, Sue Schauls, for all the work she put in to making it happen by inviting vendors, developing the printed material, filling the speaker agenda and speaking **seven times** on various topics such as Storm Water, Safety, Forklift, Airbag and the environmental panel with other experts. I think our neighboring states found out how easy compliance is for us in Iowa!

I keep hearing that parts sales are slow but somehow that hasn't freed up any time for me or any of my fellow recyclers! I say that somewhat tongue-in-cheek as I have yet to get any "takers" on my goal of highlighting members



Dear Santa,
Please bring me good clean used
auto parts from a SALVAGE
FACILITY

Specializing in Non-OEM Body Parts for all makes and models of Cars & Trucks



EXPRESS PARTS

5 LOCATIONS TO SERVE YOU!

Ottumwa, IA • Lansing, IA
Waterloo, IA • Rochester, MN
Inver Grove Heights, MN

800-258-8885

We Pledge to: ♦ Provide the Training and Support you want to keep your staff the best informed.

♦ Provide a Quality Delivery System for Used and OE Parts, at competitive prices.

♦ Provide Quality Care and Attention that only a **FAMILY OWNED** company can give to all our valued customers.

Check out our website at
www.wheelersautobody.com

We deliver to most of Iowa, Minnesota, and Western Wisconsin

**Full Line
PBE Supplier**

Complete inventory of Automotive Paints & Products
DuPont • Sherwin Williams • Akzo Nobel • PPG

in our Yard Profile series of articles for the IAR newsletter. Not to worry, I'm still committed to the task and will have to reach out to you! We will be asking one or two yards to take part each issue or more if it becomes a popular feature! So contact me or Sue if you are interested.

Now our focus turns to the next association activities at hand. The **Who's Who in Salvage Directory** is on the press as we speak and I look forward to seeing the new design. We set the date and location of the next summer outing for June 8-9, 2012 in Waterloo and thank Waterloo Auto Parts for hosting the dinner and dance at their yard on Saturday evening. The Vendor Show will be

bigger than ever with our growing associate member list and requests for invitations that Mike and Sue received while attending the national convention. I know it will be another great event and I look forward to seeing our members and guests next summer. For now though, we are settling in to our winter routine and preparing for the holidays, the granddaughter will make this one special for both Sheila and I!

Merry Christmas and Happy New Year,
Brent Nugent, PRESIDENT
Iowa Automotive Recyclers

From the Desk of the Executive Director

You Don't Know WHAT You Don't Know By Sue Schauls



I get so much out attending the national Automotive Recyclers Association (ARA) conference each year that I urge all of you to consider going to Orlando, Florida next October 24-28, 2012.

The one point that resonates with me is that feeling of "You Don't Know WHAT You Don't Know." But sitting in great sessions for four straight days will certainly make you feel humble and then collectively you will feel educated and engaged in the future of auto recycling!

The other aspect I thoroughly enjoy is the meeting and sharing of information among other recyclers from throughout the US, Canada and the world. Yes, I know they call this NETWORKING but that cliché word does not fully express the benefits I receive from interacting with recyclers at the convention. Maybe networking does not convey the family-oriented green industry that we all understand IS automotive recycling. And I believe that is 100% due to the people working in our industry. That is what prompted me to begin this year with our annual "Good Will" edition of the newsletter. I chose these mem-

bers and these activities to highlight the good will that is spread from the local automotive recycling facility, its owners and families involved in the community. I hope that this edition inspires you to share your story next year!

**Merry Christmas and Happy
New Year! Sue**

Membership Renewal Reminder!



It's that time of year again! Well yes, it is the Holiday Season but it is also time to renew your membership in the IOWA AUTOMOTIVE RECYCLERS association. Thank you for your prompt response!

The Iowa Automotive Recyclers News

Now we must stop to mourn the loss of one of the IAR family, Bryce Dryfhout, son of Holli and Bill from Lems passed away in late September. Sadly Bryce lost his battle with cancer not long after his Grandfather Don Kelderman, also from Lems, passed away earlier in the month of September. Our sympathy goes out to the crew at Lems Auto Recyclers in Doon, Iowa and the Dryfhout family. Many of your generous donations of auction items and table decorations helped raised the \$3,000 the Iowa Auto Recyclers donated to Bryce during the last Summer Outing in Tama, Iowa. Ours was but

one of many fundraisers that helped Bryce through his battle with cancer, undoubtedly due to the courage and character of this young man. Cancer is a devastating disease, especially in children. It dramatically changes the lives of entire families and alters their childhood experiences.

References:

1. <http://iagenweb.org/boards/sioux/obituaries/index.cgi?read=355379>
2. http://south.sanfordhealth.org/classlibrary/page/_staticinclude/Focus%20Winter2007.pdf

Spilman Auto Parts Spreads the Love

Spilman Auto Parts in Bloomfield, Iowa supports their local community through a variety of sponsorship activities. One unique approach is to introduce students to the automotive recycling industry through school field trips!

Spilman Auto Parts is committed to youth sponsorship. They buy uniforms for the Little League and Babe Ruth baseball teams and sponsor many high school sports. Spilman Auto Parts also buys a cow, pig and sheep at the local 4H Livestock Auction each year as one more way of showing community support. Eric Piper of Spilman Auto Parts says "being involved in a variety of local community and student sponsorships is important



to him and his father and partner, Rick Piper."

The entire Piper family is committed to community support. Spilman Auto Parts also sponsors the races and the rodeo at the county fair.

Financial support isn't the only donations made either. Each year Spilman Auto Parts donates cars for local emergency service training

and to destroy for homecoming "stay-safe" awareness. They have also donated cars for raffle for the homecoming and the little league in the past. Reaching out and being involved is one of the hallmarks of the automotive recycling industry and the Spilman Auto Parts is a great example!



Thank you to all of the 2011 CMARC Sponsors

Event at the President Abraham Lincoln Museum Cocktail/Auction Reception Sponsored By:

Car-Part.com/Checkmate by Car-part.com
URG Pinnacle Professional
Hollander, A Solera Co.

Marketing Material Sponsored By:
RJ McClellan, Inc.

CMARC Golf Outing Sponsored By:
Legends Smelting & Recycling
Golf Hole Sponsors:

Iowa Automotive Recyclers
Trails End Auto & Truck Salvage
Chicago Industrial Catalytic
I-55 auto Salvage
Brock Supply
No Fee Salvage.com
Ray's Auto Parts
RAS Core
Logan Oil
ABC Auto Parts & Sales
Al-Jon Manufacturing
Auto & Truck Recyclers of IL
Automotive Recyclers of IN

Friday Breakfast Sponsored By:
IAA, Insurance Auto Auctions

Saturday Breakfast Sponsored By:
LSB Insurance

Friday Lunch Sponsored By:
Market Financial Group

Saturday Lunch Sponsored By:
LKQ Corporation

Friday Afternoon Break Sponsored By:
Salvage Direct

Saturday Afternoon Break Sponsored By:
Miller Compressing Company

Friday Afternoon Trainings Sponsored By:
Auto Data Direct

Thank You for Your Support!!!!!!!





Thank You to All of Our Exhibitors for the 2011 CMARC and Trade Show! Bringing You the Best in the Central Midwest!!!

Auto Data Direct, Inc.
1379 Cross Creek Circle
Tallahassee, FL 32301
ph: 850/877-8804

Rebuilders Automotive Supply
1650 Flat River Rd
Coventry, RI 02816
ph: 401/822-3030

URG & Pinnacle Professional
67465 Revere Pkwy Suite 120
Centennial, CO 80112
ph: 303/367-4391

Car-part.com
1908 Highland Pike
Ft Wright, KY 41017
ph: 859/344-1925

Checkmate/ By Car-Part.com
1908 Highland Pike
Ft Wright, KY 41017
ph: 859/344-1925

Market financial Group
240 Commerce Dr.
Crystal Lake, IL 60014
ph: 630/674-6433

Legend Smelting & Recycling
2520 Sweetwater BLVD
Spring Valley, CA 91978
ph: 815/641-7661

Knopf Automotive
93 Shrewsbury Ave
Red Bank, NJ 07701
ph: 404/691-0777

Hollander, a Solera Co
14800 28th Ave N. #190
Plymouth, MN 55447
ph: 763/553-0644

Automotive Recyclers Association
9113 Church St.
Manassas, VA 20110-5456
ph: 577/208-0428

Fields Environmental, Inc.
1309 West Vernal Pike
Bloomington, IN 47404
ph: 812/333-5333

Snyder Insurance
#1 Brickyard Drive
Bloomington, IL 61701
ph: 309/275-9987

MCI Cores6346 Plymouth
St. Louis, MO 63133
ph: 314/581-2970

Crush Software
445 East 200 South, Ste 140
Salt Lake City, UT 84111
ph: 801/953-1003

The Connection
1019 Harrin Pkwy Suite 120
Rockledge, FL 32955
ph: 800/848-4850

Buddy Automotive Innovations
16 Via Maria Theresa
Manitou Springs, CO 80829
ph: 866/337-1177

Al-Jon MFG LLC
15075 Al-Jon Ave
Ottumwa, IA 52501
ph: 641/455-5616

Salvage Direct
PO Box 138
Eldridge, IA 52748
ph: 563/823-6509

Logan Oil
9888 Waples St. Suite B
San Diego, CA 92121
ph: 858/558-9440

Induction Innovations
PO Box 788
Libby, MT 59923
ph: 406/291-0498

The Rogers Group
2355 Iroquois Dr.
Glenview, IL 60026
Ph: 847/562-9766

SAS Forks
PO Box 260
Luxemburg, WI 54217
Ph: 920/845-2307

ENR United Road Towing
16325 Crawford Ave
Markham, IL60428
Ph: 708/333-7300

Olston's Auto Recyclers
3450 N. 35th St. Cir.
Lincoln, NE 68504
Ph: 402/467-4541

Morgan Stanley Smith Barney
70 W. /Madison Suite 300
Chicago, IL 60602
Ph: 312/827-6658

Omni Source Corp
2205 S Holt Rd
Indianapolis, IN 46241
Ph: 360/437-0443

Clean Burn
1860 Charter Ln
Lancaster, PA 17601
Ph: 717/656-2011

Power Plus Products
6410 W. 74th St
Bedford Park, IL 60638
Ph: 773/788-9947

Reach Local
230 W. Monroe Suite 700
Chicago, IL
ph: 312/244-3600 ext. 111



Dealer Education Reminder

The end of the calendar year will be here and gone before we know. I want to remind all the Used Car Dealer license holders that the deadline for taking the continuing education Dealer's Education Class is December 31, 2012. Every used car dealer must take the class in 2012 by December 31st, even if you took the class in another month of 2010 you still have until the end of the calendar year to get the required continuing education credits. Our associate member, the Iowa Independent Auto Dealers Association (IIADA) has gone to great length to make classes available to used car dealers through the local community college. Check the location, dates & time and course offerings at http://www.iowaiada.com/en/dealer_education.cfm.

The **Environmental & Safety for Automotive Dealers** class that I teach is offered throughout the next year at all of the local community college campuses. If you have not yet received your I-CARE audit then my class will be of great benefit to you and give us a chance to meet as well. If you have achieved your I-CARE certification and just want to enhance your understanding of the environmental and safety regulations then my class is the place for you. **It should also provide you with the opportunity to network with local repair shops and used car dealers that can become your customers or associate members to our organization.** Hope to see you there!

Announcing...
IRT is NOW...
ISO 14001:2004 Certified

IRT
 INTEGRATED
 RECYCLING TECHNOLOGIES INC.

Your Reliable Consumer of
Catalytic Converters and High Grade Electronic Scrap

Call Today for Competitive Non-Ferrous Pricing.

877-892-9194

763-295-6992

9696 Fallon Ave. // Monticello, MN

Fax 763-295-6982 // www.irtmn.com





“PartsView has given us a better picture of the product we sell to our customers. Through 2D or 3D imaging we are better prepared to answer and supply the customer with information and parts. By allowing our sales team to better view the product break outs we can educate the customer on additional pieces needed for their specific needs, **increasing our sales...**”

Terry Westedt, Weller Auto Parts Inc.

PartsView™

Next Generation Parts Identification Tool

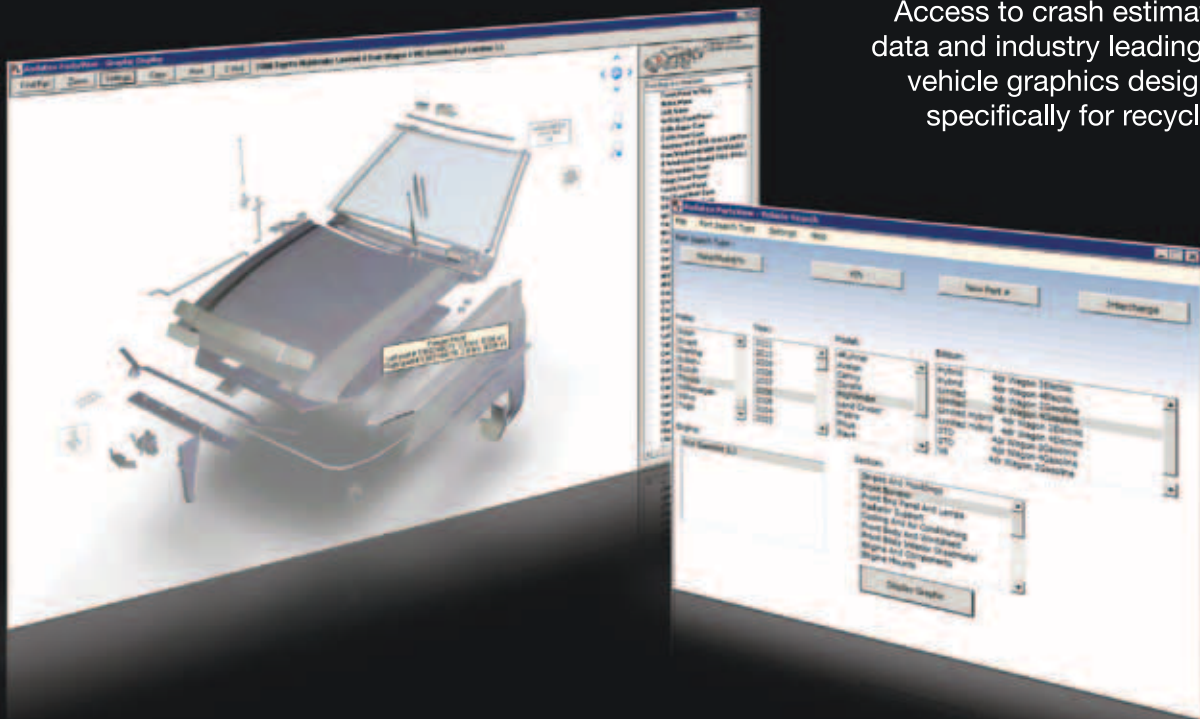

Access to crash estimating data and industry leading 3D vehicle graphics designed specifically for recyclers.

Audatex®, Hollander's sister company, just launched its' vehicle graphics program, **PartsView**, which has the same information used by insurers and body shops to create damage estimates but designed specifically for **use by recyclers**.

Contact us TODAY!

800-825-0644

www.hollandersystems.com
hollandersales@audatex.com

Dale Swift Fund Spreads Christmas Cheer



Here is a summary list of the individuals and families for whom holiday-time support and gifting was generously provided by **Dale Swift Fund** donations for the 2010 Christmas season;

- A 34-year old mother of a 22 month old, she has malignant melanoma spread to the brain;
- A 30-year old father of 3 boys with Hodgkin's lymphoma, included gift card and remote control cars;
- A 38-year old mother of 5 with widely metastatic breast cancer to brain;
- A 37-year old divorced mother of 2 with recurrent breast cancer who received personalized gifts selected by the Swift / Roush clan for the patient, son and daughter with the guidance of the patient's mother;
- A 62-year old widow with recurrent uterine cancer who enjoys fishing received a Bass Pro Shop gift card including an unused card from Dale himself!!!
- A 42-year old lady with vulvar cancer, who is a single mom with 2 children;
- A 33-year old mom with cervix cancer;
- A 26-year old mom with advanced breast cancer, she and her two children received hand-selected gifts from the Swifts / Roushes that in total, almost filled a small room! It was quite a site;
- A 42-year old mom with cervix cancer;
- A 26-year old mom with a young son, receiving radiation and chemotherapy for cervix cancer;



ADD is your source for salvage vehicle reporting and live customer support.

Any business handling/dealing with 5 or more salvage vehicles is required by law to report salvage vehicles to the National Motor Vehicle Title Information System (NMVTIS).

Auto Data Direct makes this as EASY as 1-2-3, and provides many other useful services!

For additional information, visit our website at **ADD123.com** and select Salvage Reporting.

Enter promo code RJMC11 to receive \$25 off account activation (Expires December 31, 2011)



AutoDataDirect, Inc.

ADD123.com

The Iowa Automotive Recyclers News

- A 57-year old lady with cervix cancer, recent major surgery made her unable to come to clinic, gift card was mailed to her home in Anita;

- A 47-year old mother of four with newly diagnosed lung cancer metastatic to brain and liver;
- A 45-year old mother of three teenage sons with widely metastatic breast cancer and failing health and worsening financial challenges; and ongoing support for a special longtime friend of the Swift / Roush family and beloved colleague of the Mercy Cancer Center Staff.



Iowa Automotive Recyclers

Your partners in advancing the auto recycling industry in Iowa!

SAVE the DATE SUMMER OUTING Waterloo, Iowa - June 8-9, 2012

The Iowa Auto Recyclers Summer Outing is our traditional gathering of members for networking and education. The "outing" format gives us the opportunity to thank our vendor members for their continued support. The amenities at the outing are supported through sponsorship.

Friday – June 8, 2012 – 6:30-9 pm

Trade Show Opening at 6:30 pm

Vendor Show with a dinner and bar service is the event for Friday networking.

Saturday – June 9, 2012 8 am – 4:00 pm

Trade Show Noon- 2:00 pm

Training Seminars & Vendor Show with Lunch

Open House Reception at Wheeler's Autobody Supply (4pm)

Bus to Waterloo Auto Parts from Hotel and Wheeler's Autobody Supply

FEATURE EVENT – Dinner & Auction followed by Band to dance the night away (6pm)

Waterloo Auto Parts Yard Tour & Dinner/Dance/Auction– Sponsored by the Osborn family

Each of these donations helped an individual or family identified to be at particular need during this difficult time and season. This list does not include almost daily (smaller amount) **Dale Swift Fund** support for patients in need of food, nutrition, supplies, travel money etc. These donations are maintained by me in a separate list.

On behalf of every individual touched and blessed by your generosity, my heartfelt thanks!!!

Sincerely,

Philip J. Colletier MD, Treasurer

The Dale Swift Fund

The Cancer Patients that receive the money have no idea who the money is coming from mostly so they don't have to worry about sending Thank you cards or paying it back. The Dale Swift Philanthropic Fund is also not tax deductible at this time but may be in the future. Dr Colletier is in charge of selecting and dispersing the funds based on his personal interaction with the patients. Since Dale's passing in October 2010 there has been over 35k in donations.

To DONATE to the Dale Swift Fund:

Attention: Gretchen Swift

Swifts Auto Salvage

1720 E Washington

Des Moines, Iowa 50316



Your Association Needs Your Help!

Legislators have lots of green issues on the table to consider.
IAR needs to have our voices heard regarding our issue -
Unregulated Buyers in the salvage pools

Your Help is Needed!!

The association is 67 members
strong & we need to fight together
on this issue...

Commit today to supporting
the IAR PAC fund. This can
be done via a one time
donation or you can be
billed via e-mail invoice or
pay pal invoice.

Our goal for 2012 is \$20,000.
Please commit your donation today!!

I want to support the Iowa Automotive Recyclers Association Pac Fund and the vital issues of the Iowa Automotive Recyclers. I am committing to a one year support of:

\$200 \$400 \$600 \$800 \$1000 \$1200.00 other \$ _____

Please bill me via e-mail and I will make full payment via mail by check

Please bill me via e-mail and I will make full payment via PayPal

I want to make payments for my donation (please specify amount and when)

Amount: _____ When: _____

Please fill out for your donation to the Iowa Automotive Recyclers PAC fund.

Name: _____

Address: _____

E-Mail: _____ Phone # _____

Please Fax completed commitment form to 563-556-5097.

Donations need to be made via cash, personal check, money order or non-corporate check. If paying via Paypal the donations will need to be made from a personal or non-corporate business account. Donations need to be made out to IAR PAC and mailed to 55 West 32nd St • Dubuque, Ia, 52001.

Any questions please call Jodi at 563-556-0044 or e-mail iarpacfund@gmail.com.

Vander Haag Giving a Bounty

Each year Vander Haag's Inc. contributes to the Automotive Recycling Association (ARA) Scholarship Foundation, Vander Haag Scholarship fund. Their generosity assists in providing students with funds to further their post-high school education. The recipient does not need to be a Vander Haag employee's child. The scholarship can go to anyone in the association. Selection is based on GPA and other items provided on the application. There is a committee within the association that chooses who is awarded the scholar-



in our immediate area. At that time, no residential, educational, or work service opportunities were available.

In 2011, Hope Haven:

- Provides services that meet the diverse needs of more than 1,400 children and adults from 47 of Iowa's 99 counties and 10 counties in Minnesota.
- Through Hope Haven International Ministries, wheelchairs were delivered to people in desperate need of mobility and opportunity in 106 countries around the world, logging over 1.5 million volunteer hours since 1994.
- Over 490 adults celebrate living in their adult residential sites.
- Thanks to Hope Haven's Vocational and Employment programs, over 390 adults enjoy holding jobs in work services, such as facility-based employment, community-based employment or day habilitation.
- Almost 600 people are served in our Children and Family Services through mental health, child welfare, family unity, counseling, and residential settings.
- There are 290 adults who participate in the Psychiatric Rehabilitation Programs in seven communities, including Key to Success, Mental Health, Peer Support, and Psychiatric Consultation.

Hope Haven is accredited and highly commended for quality services by the Commission for the Accreditation of Rehabilitation Facilities (CARF). To donate:

Hope Haven, Inc.
1800 19th Street PO Box 70
Rock Valley, IA 51247
712.476.2737

The Automotive Recyclers Association maintains the Scholarship foundation for the benefit of members and the industry. For more information, contact ARA Headquarters at (571) 208-0428.

ship. For more information see <http://www.a-r-a.org/content.asp?pl=505&sl=438&contentid=443> or to download the application.

In addition to the ARA scholarship, Vander Haag's provides an additional scholarship opportunity for all our employees and dependent children for further education.

Vander Haag's also provides Hope Haven with the use of a grain truck each fall for use in collecting grain donations for their ministries. Hope Haven assists disabled people young and old with a variety of opportunities, from housing and work training and employment opportunities to their International Wheel Chair Ministry, which provides wheel chairs to those in need all over the world.

The Hope Haven ministry began in 1964 when we responded to the needs of 11 children with hearing impairments

Iowa Automotive Recyclers Support Local Fire Education Programs

Iowa Automotive Recyclers support their local Fire Departments by donating salvage vehicles to the education of fire and rescue first responder's educational programs. Through the donation the emergency personal can learn how to extinguish a vehicle fire and practice the use of the 'jaws of life.' The experience gained through this hands-on training is invaluable during an actual emergency event. We are proud to support fire education. Some of our members that donate to this wonderful cause are:

Walker Auto Salvage, inc., Waverly, Iowa. Gary Waler reports that Walkers support numerous local fire departments throughout the year furnish-

ing cars to train EMT's for 'Jaws of Life' use.

North End Auto Wrecking, Dubuque, Iowa. Jodi Kunde reports that North End donates cars to several fire departments for practice.

Midwest Auto Parts, Inc., Waterloo, Iowa. Jamie Aikey reports that Midwest Auto Parts is a big part of the annual hazMat training function in Waterloo each year.

Trail's End Auto & Truck Salvage, Des Moines, Iowa. Mike Swift says the Des Moines Fire Department and Trail's end staff have fun when they fire department comes on-site to "set cars on fire."

North End's FAY ORCUTT Memorial Scholarship

Each year North End Auto Wrecking in Dubuque, Iowa contributes to the Automotive Recycling Association (ARA) Scholarship Foundation, Fay Orcutt Scholarship fund. Fay Orcutt was the founder of the business and the current North End team wanted to honor his memory by providing students with funds to further their post-high school education.

To download the application or for more infor-

mation see <http://www.a-r-a.org/content.asp?pl=505&sl=438&contentid=443>.

The Automotive Recyclers Association maintains the Scholarship foundation for the benefit of members and the industry. For more information, contact ARA Headquarters at (571) 208-0428.

North End also donates cars to several fire departments for practice each year.

SUPPORT OUR ASSOCIATE MEMBERS

Al-Jon, Mfg.
641-682-4506
800-255-6620

Alter Metal Recycling
515-262-0764
800-344-2947

Auto Data Direct
850-877-8804

Behr Mason City LLC
641-424-9521

Car-Part.com
859-344-1925
800-347-2247

DeVries Equipment
515-964-2299

Donate A Car 2 Charity
877-505-5775

EZ Crusher
320-274-3594

Full-Line Core
812-447-0746

Gerdau Ameristeel
563-732-4618

Global Parts Solution
414-861-8442

Holiday Wrecker Service, Inc.
319-351-9091
800-383-9091

Hollander
763-553-0644
800-825-0644

I Buy Converters Too LLC
815-409-5252

IIADA
641-755-4177

Integrated Recycling Technologies
763-295-6992
877-892-9194

Legend Smelting & Recycling
815-641-7661
(I Buy Convertors Too)
815-409-5252

The Locator Magazine
712-458-2213
800-831-0820

Logan Oil
858-550-9440

LSB Financial
319-268-4242

Metro Salvage Pool
515-266-5196

Nordstrom's Automotive
605-594-3910
800-272-0083

Pal Fleet Truck Equipment
712-323-7116

Pam's Auto
800-560-7336

QCSA Auto Auctions
563-285-2070

QRP Salvage Solutions
715-551-3759
888-241-0294

Quad City Salvage Auction
563-285-2100

Recycled Parts Plus
866-837-2039

RJ McClellan, Inc.
877-525-4589

S & L Auto Parts, Inc.
641-521-0156

Shine Bros. Corp.
712-262-5579
800-262-5579

Sioux City Compressed Steel
712-277-4100

Washer Systems of Iowa
515-289-1844

Wheeler's Auto Body Supply
888-294-1320

Are you a Member yet?

**If Not, Join Today and Start
Enjoying All the Benefits!**

(641) 484-2057
(800) 542-7880 IA Watts
(641) 484-5555 Fax
parts@sandhillautosalvage.com



Sandhill Auto Salvage

Hours:
Mon-Fri 8AM to 5PM
Sat 8AM to 12Noon

1981 Hwy. E-64
Tama, Iowa 52339

The Future Has Arrived

At the recent Automotive Recyclers Association convention I presented the new Hybrid Vehicle Dismantling Guide. The presentation and the guide were the fruition of a two-year project of the ARA Technical Advisory Committee. The project team was made up of Chairman, Chuck Ossenkop, Northwest Auto Parts in Anchorage, Alaska, Betsy Beckwith, the ECAR Center (Environmental Compliance for Automotive Recyclers – <http://www.ecarcenter.org>) website manager and ARA Government Affairs staffer, and myself, Sue Schauls of the Iowa Automotive Recyclers and the Iowa – Certified Automotive Recyclers Environmental (I-CARE) Program.

We each presented a portion of the new material with Chuck delivery the very detailed technical stuff. At one point I described the difference between a FULL and a MILD hybrid vehicle.

Basically, a FULL hybrid vehicle is a gasoline and electric powered vehicles that share the task of supplying power to the components and functions of the vehicle. A MILD hybrid vehicle is a typical internal combustion engine car that has integrated hybrid technology into the system such that electronic power controlled units like power steering or air conditioning are now powered by electric motor generators for improved fuel efficiency.

In the future more and more vehicle designs will include the innovative technology born of hybrid design making their way in to conventional vehicles bringing to market more MILD hybrid options. The very next day the October 15th weekend edition of the USA Today featured a story on page 3D about “the new Buick La-Crosse mild hybrid, gas-electric drivetrain for big Buick sedans, priced the same as the V6 gas model, but rated 6 mpg better.” The future has arrived.

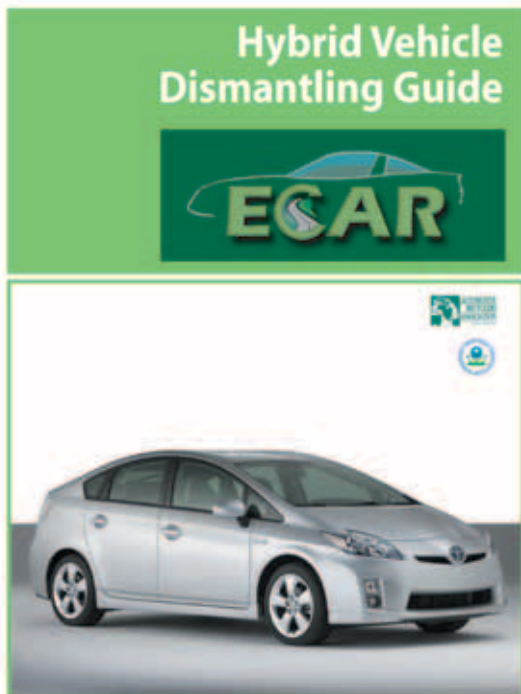

"By the end of 2016, J.D. Power and associates expects there to be 159 hybrid and electric vehicle models available for purchase in the U.S. market. This is a significant increase from only 31 hybrid and electric models in 2009."

Why Create a Hybrid Vehicle Demander's Guide?

Not since 1981, when computerized engine management systems began to appear on US highways, has technology changed so much in the automotive world. The introduction of the Hybrid Electric Vehicle has brought high voltage battery packs, inverters, special cooling systems, complex braking systems and electric motor generators into mainstream technology over the past decade.

This manual will help all technicians in the recycling trade, both those with limited experience in handling and dismantling hybrid vehicles and those who have yet to open the hood on a hybrid, gain essential knowledge on safety, theory of operation and practical tear down procedures.

Clean diesel, smaller more efficient turbocharged engines are coming to market as part of those expanding technologies but pale compared to the focus on hybrid technology. Hybrid electric vehicles are NOT a passing fad. They are more fuel efficient and pollute less than conventional vehicles. Hybrid electric vehicles are not only here

to stay, they are growing in numbers. Just visit any NADA (North American Auto Dealers) car show and ask each manufacturer what their plans are for hybrid offerings. None out of the ten will tell you that they are going to either start a hybrid program or will be dramatically increasing their hybrid programs.

As fuel prices creep up and up from reasons ranging from supply and demand to instabilities in various oil producing nations, the push for higher efficiency from automotives will move up to meet the challenge. Combine the economic factor with the ever increasing demands by government agencies and consumers to see automobiles pollute less, and we have the perfect environment for expanding technologies in the transportation industry. According to a 2009 study, there have been over 1,600,000 hybrids sold. Therefore, it is safe to assume that there are nearly this many hybrids on the road considering the first year hybrids were mass produced was 2000. For ten years the number of hybrids on the road has grown from 17 to over two million.



The publication HYBRID-VEHICLE-DISMANTLING-GUIDE was developed under Cooperative Agreement No. OPA-08CA-02-10-01 and OPA-FR-08-00 awarded by the U.S. Environmental Protection Agency. It has not been formally reviewed by EPA. The views expressed in this document are solely those of Environmental Compliance for Automotive Recyclers (ECAR), compliance assistance center and IARA does not endorse any products or commercial services mentioned in this publication. The ECAR Center is a "not-for-profit" for all automotive dismantling and recycling operations and provides comprehensive and up-to-date environmental compliance assistance.

<http://www.ecarcenter.org>

Hybrid Vehicle Dismantling Guide Highlights

A hybrid electric vehicle works like this:

1. Gasoline is stored in a fuel tank for use in the internal combustion engine.
2. Electricity is stored in a high voltage (HV) battery pack used to power the electric motor(s).
3. One or both sources are used to power the vehicle.

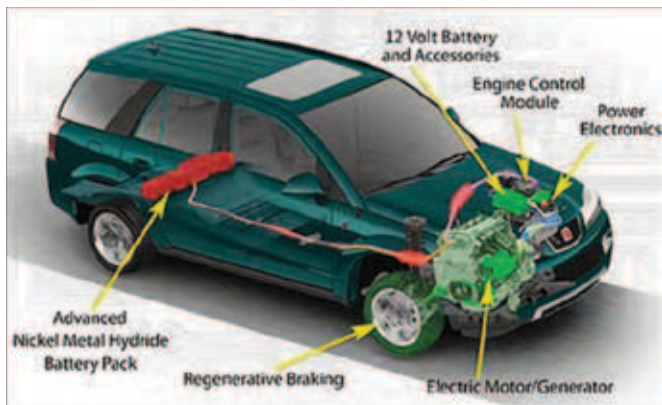

By the end of 2016, J.D. Power expects there to be 159 hybrid and electric vehicle models available for purchase in the U.S. market. This is a significant increase from the 31 models in 2009.

Key terms in HEV technology:

The Continuously Variable Transmission or CVT is located between the gas engine and the electric motor. Honda called it INTEGRATED MOTOR ASSIST or IMA.

REGENERATIVE BRAKING is the vehicle's

ability to use the electric motor as a generator by capturing energy of friction normally lost in braking.

HEV Power Systems

Hybrids are classified by the division of power between sources. Both sources (electric motor and gas engine) may operate in **PARALLEL**, to simultaneously provide acceleration, or operate in **SERIES** with one source exclusively providing the acceleration and the second being used to enhance power. A **Series-Parallel** system is also possible with one primary power source and the other providing direct additional acceleration if required. *Accessories such as power steering and air conditioning are powered by electric motors.*

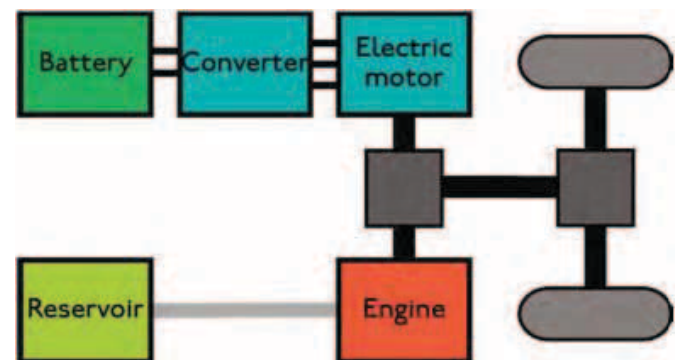

Parallel System

- Most common in HEV.
- Engine and electric motor connected to mechanical transmission.
- Use one electrical motor/generator as second power source and replaces starter & alternator (often located between engine and transmission).

Series System

- Referred to as Range-Extended Electric Vehicles.
- Driven by electric traction.
- The engine drives the generator and not the wheels.
- Electric motor matched to wheels, does not require transmission between engine & wheels.

Types by Degree of Hybridization

FULL Hybrid is a vehicle that can run on just the engine, just the batteries or a combination of both.

MILD Hybrid is basically a conventional vehicle with some degree of hybrid hardware but with limited features.

Hybrid Electric Vehicle Hazards

In addition to usual automotive hazards of flammable gasoline, 12 volt electrical shorts/fires and non-deployed airbags, HEV have high voltage safety issues.

For this reason cables on HEV are either

1. BLUE (42-volt) use CAUTION or
2. ORANGE (60-volt) use EXTREME CAUTION.



Create a buffer zone of a 3-foot perimeter with caution tape that does not have any metal items in it. Wear insulated gloves such as OSHA-approved "lineman gloves" and use a CAT III Meter.

Hybrid Electric Vehicle Safety Precautions

The right tools are absolutely mandatory:

1. Class 0/1000 Volt GLOVES
2. CAT III 1000 Volt digital multi meter (DMM)
3. Safety Glasses with side shields
4. Linesman type high voltage rescue hook

TRAILS END

**Auto and Truck
Salvage**

Happy Trails To You!



The best value. The best price. The best service.
*When you need quality used auto & truck parts,
look no further than Trails End.*

Phone: 515-265-5696

Toll Free: 800-717-6505

Fax: 515-265-0817

www.trailsendauto.com

Mike Swift • Steve Swift
1600 NE 44th Avenue • Des Moines, IA 50313

SIoux CITY COMPRESSED STEEL CO.



**2600 Boulevard of Champions
Sioux City, Iowa 51111**

*Offering full service scrap recycling
in one convenient location*

- Competitive Pricing
- Buyers of bodies, non-ferrous metals, and iron
- Prompt Payment
- Shredding, shearing, and metals processing
- Iowa-Licensed Appliance De-manufacturer on site
- Locally owned and operated for over 60 years
- Environmentally conscientious operation
- Accepting trailer loads of cut steel, unprepared, cast iron, and all metals

800-889-8848

712-277-4100 (Local) • 712-277-1210 (Fax)



Institute of
Scrap
Recycling
Industries, Inc.

Hybrid Electric Vehicle Service Disconnect Procedures

1. Turn off ignition/ press power button off.
2. Remove key from vehicle (smart key systems may allow power ups if key is in the vehicle).
3. Disconnect 12-volt battery (for added precaution).
4. Remove/ switch off OEM HV battery disconnect service device. (DO NOT handle the HV Battery without Class 0/1000 safety gloves!)
5. Test the part being removed with CAT III/1000 Volt meter.



Anything less than 15 Volts is safe to handle without gloves.

Hybrid Electric Vehicle Dismantling Guide was funded by EPA Grant EPA-OECA-OC-10-01 and CFDA # 66.305 through the Environmental Compliance for Automotive Recyclers (ECAR) compliance assistance center. <http://www.ecarcenter.org/>



Iowa Automotive Recyclers Awards Educational Scholarships (2011)

Each year the Iowa Automotive Recyclers award scholarships to assist IAR Direct member's children, and the children of their employees, with the cost of a post secondary education. Students may apply during any year they attend an accredited institution.

The school is the last expenditure upon which America should be willing to economize. ~Franklin D. Roosevelt

During this economic recession, colleges are cutting back on scholarships, grants and other forms of financial aid available to students due to funding cuts to education. That's why these scholarships are more important than ever. IAR is proud to be able to support the recipients of this year's scholarships and we invite you to –

Meet Our 2011 Scholarship Recipients!

Erin Snyder. Erin is the daughter of IAR member, Tom Snyder, owner of Snyder's Auto Body, 1526 E. Washington Street in Clarinda, Iowa. Erin is currently attending the University of Northern

From the Automotive Recyclers Association and the Environmental Compliance for Automotive Recycling Center

Hybrid Manual Dismantling Guide

Order in your choice of CD or Manual Format!

NEW!
For only **\$99**

Your Best Resource to Dismantling Hybrids



This manual will help all technicians in the recycling trade, both those with limited experience in handling and disassembling hybrid vehicles and those who have yet to open the hood on a hybrid, gain essential knowledge on safety, theory of operation and practical tear down procedures.

Order Yours Today!
Call (888) 385-1005 or
E-mail Betsy@a-r-a.org



The Iowa Automotive Recyclers News

Iowa where she is studying Early Childhood Education, with an expected graduation date of spring 2012. In order to help pay for her education Erin works concessions at college events and has two part positions she works while on school breaks. Upon graduation, Erin wants to remain in Iowa and secure a teaching position in a small town close to her family.

Megan Snyder. Megan is the daughter of IAR member, Tom Snyder, owner of Snyder's Auto Body, 1526 E. Washington Street in Clarinda, Iowa. Megan is attending Kirkwood Community College and studying Culinary Arts. Megan was a member of the National Honor Society and was involved in community services such as Adopt a Family and Food, Faith, and Fellowship. She was ranked 36 in a class of 102. Good job Megan. She hopes to work in a bakery after graduation and someday run her own bakery in her hometown.

Jessie Benson. Jessie is the daughter of Swift Auto Salvage, Des Moines, Iowa, employee, Roni Benson. Jessie plans to attend University of Northern Iowa and study Political Science or History as preparatory work for her goal of attending law school to study constitutional law. She received Academic Awards in three of four high school years, she coaches soccer and mentors students through school and church activities. We wish Jessie well as she starts her exciting academic career.

Jesse Rayevich. Jesse is the son of Stacy Rayevich, Lyle's Auto Salvage, Oto, Iowa. Jesse is attending North West Iowa Community College to pursue a degree in welding. He hopes to own a metal fabrication shop one day. Jesse was an Honor Roll stu-

dent at Maple Valley/Athon-Oto High School who will be self-financing his college education. Way to go Jesse!

Jordan Durbin. Jordan is the daughter of Jerry Durbin, owner of Osage Auto Salvage, Osage, Iowa. Jordan is North Iowa Area Community College in Mason City, Iowa to study Banking, Insurance and Financial Management. She says the experience she gained in the auto salvage business throughout her life has made an impact on her educational goals. Jordan was an Honor Roll student and participated in agricultural and nature activities. Best of luck Jordan.

2010 Scholarship Recipients

Derek Kusters. Lems Auto Recyclers, Doon, Iowa. Erin Snyder. Snyder's Auto Body, Clarinda, Iowa. Megan Snyder. Snyder's Auto Body, Clarinda, Iowa. Brooke Quandt. Quandt Auto Salvage, Carroll, Iowa. Deidra Nugent. Nugent Auto Sales, Inc., Maquoketa, Iowa.

Up to \$5,000.00 will be awarded in scholarships for the fall term (2012). Winners will be informed by mail in May of 2012. All applications must be complete and received by the IAR scholarship committee by midnight, March 15, 2012 to be considered.

Any questions regarding the scholarships and/or application should be directed to:

IAR Scholarship Committee

Attn.: Jodi Kunde

55 West 32nd Street,

Dubuque, Iowa 52001

iarscholarship@gmail.com

Deadline date is March 15, 2012 for 2012 Scholarships.

ARA Member employee's children are also eligible for the annual ARA Scholarship Foundation program. For more information and the application visit:

<http://www.a-r-a.org/content.asp?contentid=443>



ACTION AUTO PARTS

**WE ARE YOUR AUTO & TRUCK SALVAGE SOURCE
FOREIGN & DOMESTIC - USED - REBUILT & NEW PARTS**

LET US \$AVE YOU MONEY

100 S. 18TH Ave., PO Box 264
Marshalltown, Iowa 50158
www.action-auto-parts.com

641-752-3395
800-373-3995
fax: 641-752-6239

Iowa Auto Recyclers Association Scholarship

APPLICANT CRITERIA:

- Be a graduating high school senior or equivalent, or a college student who has been accepted to an accredited university, state college, community college, business or liberal arts school
- A minimum 3.0 GPA during high school or first year college.
- Applicants (or their eligible dependent/relative) must be affiliated with the Iowa Auto Recyclers Association to participate. EITHER:
 - Be a recycling yard owner or relative of the recycling yard owner who is a direct member of the Iowa Auto Recyclers. The owner of the recycling yard must be employed at the recycling yard, and not at other enterprises owned by the recycling yard.
 - "Relatives" may include a son, daughter, grandchild, son-in-law, daughter-in-law, or spouse of the owner.
 - Brothers, sisters, uncles, aunts, nieces, or nephews of the owner will not be eligible to participate unless employed in the business.
 - OR
- Be an employee or dependant of an employee of the member yard who has been employed for one year or more.
- Applicant must remain a degree-seeking student, enrolled at least full-time (a minimum of 12 credit hours per term).

APPLICANT GUIDELINES:

- Complete full application
- Enclose an official copy of the applicants' high school transcripts (in separate sealed envelope) with application.
- Include a one to two page essay on the following topic:

What do you think the industry of Auto Recycling will be like in the next 10 years?

- Two recommendation forms filled out from a school counselor, school official, employer or high school teacher who is familiar with the applicant.
- Applicants must remain enrolled in the same accredited four-year college, accredited university, state college, community college or business or liberal arts school for at least one year after accepting scholarship funds to be eligible for the full award.
- Obtain a letter from your parents' employer confirming date of hire with the firm. Your parent must have been or will be employed with a full member of the Iowa Automotive Recyclers for at least one year prior to application.

All candidates will be required to submit a complete application package, which includes a completed application form, transcripts, essay and two recommendation forms to: **IAR SCHOLARSHIP COMMITTEE**
ATTN: JODI KUNDE 55 WEST 32ND STREET DUBUQUE IA 52001, you can e-mail any questions to Jodi at iar-scholarship@gmail.com.

DEADLINE DATE:

The deadline for receipt for all application materials must be received by the IAR scholarship committee by midnight MARCH 30TH. Up to \$5000.00 will be awarded in scholarships for the fall term. The winners will be notified in writing in May 2012 and will be posted on the IAR website.

The scholarship award check will be forwarded to the scholarship recipient's school upon written certification of his/her enrollment for the fall term of the year the scholarship was granted. If the scholarship winner does not provide enrollment verification for the fall term the scholarship monies will be forfeited.

SCHOLARSHIP SELECTION:

The scholarship will be awarded based on review of the following: coursework in high school, course distribution, activities, the one page essay and recommendations. **Standardized test scores will NOT be used as a factor in the selection process.**

Iowa Auto Recyclers Association Scholarship

NAME: _____
(First) (Middle) (Last)

MAILING ADDRESS: _____

HOME PHONE: _____ E-MAIL ADDRESS: _____

DATE OF BIRTH: _____ GENDER: MALE / FEMALE

CURRENTLY ATTENDING: _____
(INDICATE HIGH SCHOOL OR OTHER SCHOOL)

HIGH SCHOOL HONORS, AWARDS, AND ACTIVITIES: _____

COMMUNITY SERVICE AWARDS AND ACTIVITIES: _____

STATE YOUR FINANCIAL NEED, WHAT PORTION OF EDUCATION FUNDED BY YOURSELF: _____

SCHOLASTIC INFORMATION:

ACT TEST SCORE: _____ SAT TEST SCORE: _____

RANK IN CLASS: _____ OF _____ CURRENT GPA: _____

HONORS AND AWARDS (STATE NATURE AND YEAR OF AWARD OR HONOR): _____

OFFICES AND POSITIONS OF LEADERSHIP (STATE NAME OF ORGANIZATION AND YEAR, EX: BAND 9, 10)

WHAT ARE YOUR SHORT AND LONG-TERM CAREER OBJECTIVES? _____

WHAT DO YOU SEE YOURSELF DOING FIVE YEARS FROM NOW? _____

ANY ADDITIONAL INFORMATION WHICH MAY BE USEFUL TO SCHOLARSHIP COMMITTEE: _____

SCHOOL YOU WILL BE ATTENDING: _____

ANTICIPATED MAJOR: _____ EXPECTED GRADUATION DATE: _____

NAME OF PARENT WHO HAS BEEN EMPLOYED BY A DIRECT MEMBER OF IAR FOR AT LEAST ONE YEAR?

START DATE? _____

WHICH DIRECT MEMBER/YARD ARE YOU AFFILIATED? _____

NOTE: transcripts, essay, and recommendation forms should accompany scholarship application.

APPLICANTS SIGNATURE: _____ DATE: _____

Recommendation Form

Iowa Auto Recyclers Association Scholarship

NAME OF APPLICANT: _____

SCHOOL: _____

HOW LONG AND IN WHAT CAPACITY HAVE YOU KNOWN APPLICANT: _____

PLEASE STATE WHY YOU FEEL THIS APPLICANT WOULD BE A GOOD CHOICE AS A RECIPIENT OF THIS SCHOLARSHIP?:

HOW FIRM IS THE APPLICANT'S COMMITMENT TO HIS OR HER CAREER: _____

SIGNED: _____ DATE: _____

TITLE OR POSITION: _____

SCHOOL VERIFICATION

AS OF: _____ THE STUDENT LISTED ABOVE HAD A GRADE POINT AVERAGE OF: _____

ACT TEST SCORE: _____ SAT TEST SCORE: _____ RANK IN CLASS: _____

OF STUDENTS IN APPLICANTS CLASS: _____

SIGNED: _____ POSITION: _____



Greenhouse-Gas-Friendly Refrigerant Replacement 1234yf

HFO-1234yf or 2,3,3,3-Tetrafluoropropene, is a fluorinated hydrocarbon that is the proposed replacement for R-134a as a refrigerant in automobile air conditioners.

HFO-1234yf is the first in a new class of refrigerants developed to have almost no environmental impact, acquiring a global warming potential (GWP) rating 335 times less than that of R-134a and an atmospheric lifetime of about 400 times shorter. It was developed to help automakers meet European regulations that go into effect in 2011 requiring that all new car platforms for sale in Europe use a refrigerant in its AC system with a GWP below 150.

HFO-1234yf, could be used as a “near drop-in replacement” for R-134a, the current product used in automobile AC systems. This means that automakers would not have to make significant modifications in assembly lines or in vehicle system designs to accommodate the product. HFO-1234yf has the lowest switching cost for automakers among the currently proposed alternatives, although the initial cost of the product is much higher than that of R134a. The product could be handled in repair shops in the same way as R-134a, **although it would require different, specialized equipment to perform the service.** One of the reasons for that is the mild flammability of HFO-1234yf.

Shortly after confirmation from automakers that HFO-1234yf would be adopted as a replacement of R134a automotive air-conditioning refrigerant, Honeywell and DuPont announced that they will jointly build a manufacturing facility to produce HFO-1234yf. The new plant will be ready to supply commercial quantities of 1234yf sometime

in 2011. Although others claim to be able to make and sell 1234yf, Honeywell and DuPont hold most or all of the patents registered for HFO-1234yf. On July 23, 2010, General Motors announced that it will introduce HFO-1234yf in 2013 Chevrolet, Buick, GMC and Cadillac models in the U.S.

Although the product is classified slightly flammable, several years of testing by SAE proved that the product could not be ignited under conditions normally experienced by a vehicle. In addition several independent authorities evaluated the safety of the product in vehicles and all concluded that it was as safe to use as R134a.

Once the product has become widely used in US market vehicles, auto salvage facilities should maintain a copy of the Material Safety Data Sheet (MSDS) in their Safety Program/MSDS binder as is the common practice for all evacuated product. Download the 1234yf MSDS at <http://www.sue-schauls.com/HFO-1234yf.pdf>.

Find the most common auto recycling product MSDSs in the MSDS Library <http://www.sue-schauls.com/MSDS.html>.



Midwest Auto Salvage Donates Cars for Training for Firefighters



Firefighters torched tractors and chopped up cars in the name of education one Saturday last summer with the help of Midwest Auto Salvage of Waterloo, Iowa.

Midwest Auto Salvage donated cars for the drill, Murphy Tractor & Equipment Co. loaned a loader to move junked vehicles, and Hy-Vee supermarkets donated food for the event.

Crews from Black Hawk and neighboring counties attended seven classes ranging from arson investigation to high-risk rescue at Waterloo Fire Rescue's Hazardous Materials Training Center for this year's Quad-County Fire School. The curriculum was a good introduction for newly minted firefighters and a refresher course for veterans, said Capt. Michael Moore of Waterloo Fire Rescue. The school began more than 10 years ago to serve career and volunteer departments in four counties. But Moore said it has grown significantly since then and now draws students from across northeast Iowa.

The training center has a simulator that shows rescue workers the signs that deadly flashovers are about to happen. Teachers burned three late-mod-

el tractors as part of a class aimed at finding the causes of fires. There also were sessions on removal of victims from crashed vehicles, vehicle fires and rescue from a four-story radio tower.

Reference:

1. http://wfcourier.com/news/local/burn-and-learn-firefighters-ignite-tractors-cars-as-part-of/article_496fa498-3a1c-11df-bf04-001cc4c002e0.html#ixzz1ceSYKU9k

FOR MORE INFORMATION, CONTACT:

LSB FINANCIAL
PETERSEN-HILL INSURANCE



Pete Hill

VP / Commercial Insurance
Email: PeteH@MyLSB.com
Cell: (319) 240-2428



Adam Brickley

Insurance Consultant
Email: AdamB@MyLSB.com
Cell: (319) 310-6225

219 Main Street • Cedar Falls, IA 50613
Phone: (319) 268-4242 • Fax: (319) 268-4211
Toll-free: (866) 907-4242

Cody Schmit Scholarship Fund: Good Will from Tragedy

Joe and Billie Schmit, owners of JBS Auto Parts in Britt, Iowa, suffered an unimaginable loss when their son Cody passed away after a tragic accident. Cody was an active student who played football and loved to hunt and fish. But most of all Cody loved cars! He worked at the family business and developed a passion for his 1969 Chevelle and raced IMCA stock cars.

From this tragedy, the Cody Schmit Scholarship Fund was created. Cody Schmit worked hard to purchase his 2002 Chevy Silverado pickup, saving money until he was able to buy the truck he always wanted. To honor his memory, Cody's family held a raffle for the truck with all proceeds going to a scholarship fund in his name.

"(Cody) bought and paid for this truck all on his own," said Joe Schmit, Cody's father. "We wanted the money raised to go to a good cause because he was such a giving person." The drawing for the truck was held at I-35 Speed-



way in Mason City on Sept. 26, 2010. The idea to establish a scholarship fund came to the Schmit family for two reasons, Schmit said. "We just wanted any donations to go toward something that would honor Cody long-term and support education in the industry"

To give someone else the opportunity to pursue their passions through higher education, the Schmit family established the Cody Schmit Scholarship Fund at First State Bank. The **Cody Schmit Scholarship Fund** is doing well, this year the Schmits are building a tribute stock car designed by Cody before the accident. All the proceeds will all go to the fund too. The goal is at least \$5,000. The Fund gave out ten \$1,000 scholarships last year and plans to give out fifteen \$1,000 scholarships this year! Thank you to all of you who donated last year!

Cody Schmit Scholarship Fund

First State Bank

183 Main Avenue North

Britt, IA 50423-1660

(641) 843-4411

References:

1. http://globegazette.com/news/local/article_b1c009a0-9ac7-11df-bb7a-001cc4c002e0.html#ixzz1d7V9Jx9c
2. http://globegazette.com/news/local/article_60f8edde-e3e7-11df-8cb4-001cc4c03286.html#ixzz1d7YjRKi7



CHASE AUTO

Bob Schoof, General Manager

1041 Sheffield Avenue
Waterloo, IA 50702

319-234-2445 • 800-728-2568

Fax: 319-234-1977

Email: chase@qwestoffice.net

SHINE BROS. CORP.

*Small enough to know you,
Large enough to serve you.*

**Call us for top
scrap prices on:**

- Car Bodies**
- Alum. Auto Wheels**
- Radiators**
- Alternators**
- Starters**
- Harness Wire**
- & all other scrap metal**

800-262-5579

712-262-5579

Mike Mowery Ext. 123

Chris Hart Ext. 158

225 10th Avenue SE

Spencer, IA 51301

www.shinebros.com



ARA Highlights



Mike Swift Wins Regional Director of the Year Award!

Again! How proud we are to have Mike Swift as the winner of the ARA Regional Director of the Year Award 2011 and a past President of the Iowa Automotive Recyclers. An honor bestowed upon him for his enthusiasm and dedication to providing information to the Region 7 district which is made of Iowa, Nebraska, Missouri, North & South Dakota and Kansas. This is the second time Mike has earned the honor. Congratulations Mike Swift! I think an email (or two) to Mike's inbox would be a nice way to congratulate him, you KNOW THE address...

New Car Theft List Released

A newly released report from the National Highway Traffic Safety Administration (NHTSA) shows the Audi S8 headed the government's list and the Toyota Camry was the most-stolen new car in 2009. While that sounds ominous, the fact that out of 227 Audi S8's sold, 2 were stolen, puts a slightly different interpretation on it.

A close second was the 2009 Shelby GT Mustang, which had 5 stolen out of the 581 that were sold - or

a theft rate of 8.61 per 1,000 sold. Also in the top five was BMW's M5, with a theft of 7.58 per 1,000, followed by the Dodge Charger (6.47 per 1,000) and Honda's S2000 (5.60 per 1,000).

Although the report does not track light trucks, that would include SUV's, the Cadillac Escalade has been shown to top the overall list of most-stolen vehicles. On the other hand, NHTSA concludes that the overall theft rate has fallen to 1.33 per 1,000 - down from 2008 when it was 1.69 per 1,000. The general consensus is the increased use of standard anti-theft devices, vehicle parts marking as well as increased public awareness and improved prosecution efforts by law enforcement. Interestingly enough the vehicle that had the lowest theft rate is the Mercury Mariner (discontinued), which had a .08 per 1,000 rate (2 vehicles out of 25,682 sold).

Recyclers Urge FTC To Monitor Carmaker Position on Parts & Warranties

ARA filed comments with the Federal Trade Commission (FTC) urging them to monitor automobile manufacturers more closely to determine

The Iowa Automotive Recyclers News

whether they are in compliance with the Magnuson-Moss Warranty Act (MMA), i.e., are their claims unfair and deceptive. This, in response to the FTC's statement that as part of a routine review they would accept public comments on the MMA. To recap: The same concerns were raised with the FTC earlier this year, in response to automobile manufacturers implying to consumers that their warranties would be voided by using recycled automobile parts. Not only that, but automakers also implied that recycled parts were inferior to OEM parts, thus putting the consumer at risk when using them. In July 2011 the FTC sent out an alert, affirming that "Warrantors may not claim that a warranty is void simply because a consumer has used recycled part."

Tow Truck Operators Now Put on Notice to Stop Curbstoning

The organization StopCurbstoning.com is targeting Tow Truck Operators and has issued a White Paper warning them they are being watched. With their latest report, entitled "A Different Breed Of Curbstoner, And Yet Another Way Cities Leak Revenues", they want to educate the public on how rogue tow-truck companies are secretly conducting curbstoning operations, utilizing their legitimate business. Curbstoning is the repeated, unlicensed "flipping" of used cars for profit, and is illegal in most cities. Chuck Redden, president of AutoTec, one of the companies behind the Stop Curbstoning effort, wants to get the word

out - to consumers and sellers as well as the authorities. The consumer is at risk, not having a true history of a vehicle, local business are cut out of the dealing and local government does not collect fees and taxes that legitimate businesses adhere to. A statement on StopCurbstoning.com reads: "Because enforcement resources are spread thin, it's up to car buyers to be informed, automotive dealers to be proactive, and municipalities to be responsive."

NORTHEND

Auto Wrecking, Inc.
Dubuque, IA • Since 1938

800-545-8885

***Acres of used parts for
foreign & domestic cars & trucks.***



***"All cars
run on used parts!"***

www.northendwrecking.com



***One of the LARGEST
Recycled Auto Parts Facilities
West of the Mississippi!***

ARA's Technical Advisory Committee Unveils First of Its Kind - Hybrid Manual - At Convention



ARA's Technical Advisory Committee Hybrid Workgroup comprised of Committee Chair Chuck Ossenkop, committee member Sue Schauls and ARA staffer Betsy Beckwith unveiled the over 400-page spiral bound Hybrid Vehicle Dismantling Guide at an educational session during ARA's Convention.

The Workgroup walked session attendees through the guide's overview and first two model-specific chapters including a project summary, a description of general hybrid vehicle operations and a very detailed account of model specific components and their functions. Hot off the press Guides were provided to the session attendees and very shortly you also can own one of these manuals for just \$99.00. In the next few weeks, look for an order form on the ARA and ECAR websites and in your email boxes that you can print out and fax to us with your payment information and an indication of whether you want a print- or pdf-copy. So don't delay, order your guide and learn how to maximize the value of your hybrid inventory safely and efficiently. For more information, please contact Betsy at betsy@ara.org

BizUnite/ARA Marketplace Peaks Interest at Trade Show

We hope you had a chance to stop by and visit with Karen Bickerstaff in the BizUnite booth during the Charlotte convention. She came armed with lots of great information about the 30+ cost-savings programs specially designed to help you reduce costs and increase profitability. Each Preferred Vendor is carefully selected and rigorously negotiated, which combined with BizUnite's \$166 Billion Dollars in buying power, produces programs that pro-



vide unmatched value to you. Members are saving on average 20% off their total operational expenses using any combination of the programs for industrial supplies, uniforms, wireless services, shipping, payroll processing, office supplies, and more. If you were not able to visit the BizUnite booth you can still find our more information by contacting ARA. Start your savings today.



ARA Urges EPA to Continue to Exclude Scrap Metal from Definition of Solid Waste

Right on the heels of submitting comments to EPA earlier this month in which ARA strongly opposed the Agency's suggestion to include automotive waste in its updated Municipal Solid Waste Characterization Report (see related story in Oct. 18th newsletter), ARA also late last week commented on EPA's proposed revisions to its comprehensive and industry-wide vetted 2008 definition of solid waste. Specifically, ARA urged the Agency to continue to exclude recycled scrap metal from its definition of solid waste and related criteria. Under the proposed rule, EPA wants now to require legitimacy tests on scrap metal recycling - in essence applying tests for hazardous waste to non hazardous waste.

In its comments, ARA questioned the merit of

EPA's intent to require scrap metal recyclers and those who sell scrap metal for recycling to verify that the recycling process is legitimate (not a sham) on a material-specific basis. ARA asserted that under this scenario, not only would the paperwork required be prohibitive and financially burdensome, but it would also bring into question how such verifications would be interpreted by EPA. ARA went on to note that the legitimacy requirements are wholly unnecessary for processed scrap metal and that if mandated would have a chilling effect on the recycled scrap metal pipeline, wreaking economic havoc among auto-

ARA Suspicious Salvage Transaction Hotline



1-888-385-1005 x 15

Call in confidentially and report suspicious transactions occurring at salvage auctions throughout the country.

If you have a "Tip" for ARA, please call the voicemail hotline at 1-888-385-1005 x 15.

motive recyclers, scrap metal recyclers as well as end-users. Further, the Association claimed that this mandate would result in a severe decrease in the supply of scrap metal and would impede those sustainable practices that make our nation competitive in both the national and global arenas. ARA will monitor EPA's next steps on this ruling very closely.

Reprinted with permission from ARA



PAM's Auto



Professional Sales & Support Staff

PAM's Auto specializes in low mileage, late model, foreign and domestic auto parts.

- ✓ **HUGE INVENTORY**
 - Over 100,000 ready to ship parts in stock!
 - We also carry a Large Selection of OE Factory Over-Run Parts
- ✓ **QUICK DELIVERY**
 - Same day shipping on most orders!
- ✓ **FREE LIFETIME WARRANTIES**
 - Never buy that part again!

Quality Parts - Guaranteed!
Call 800.560.7336

Proud Members of:



7505 Ridgewood Rd. • St. Cloud, MN
 Local: 320.363.0000 • Fax: 320.363.9232

Shop online at www.pamsauto.com

Palfinger Hooklift hoists allow one chassis to load, unload or dump a variety of bodies. Our hooklift hoist can easily switch from a dump body, to a flatbed, to any customized body in less than 30 seconds.



PALFLEET

TRUCK EQUIPMENT

A MEMBER OF THE PALFINGER NORTH AMERICA GROUP

2109 South 35th Street • Council Bluffs, IA 51501

Tel. 712-323-7116 • 800-831-9260 • Fax 712-325-1771

www.palfleet.com

Call us at 800-831-9260 or visit www.palfleet.com

American Roll Off manufactures a complete line of single axle, tandem axle and triaxle roll-off hoists. We offer capacities of 20,000 lbs through 75,000 lbs for 10' through 26' long containers for your truck.



Iowa Automotive Recyclers

67 Direct Members

A & L Auto Parts	Holland	Nugent Auto Sales, Inc.	Maquoketa
Ace Auto Recyclers	Iowa City	Osage Auto Salvage	Osage
Action Auto Parts	Marshalltown	P.Q. Auto Parts	Sioux City
Aikey Auto Salvage	Cedar Falls	Pat's Auto Salvage	Waterloo
AWE Auto Service	Traer	Poell's Enterprises, Inc.	De Witt
B & B Salvage	Sioux Center	Powerhouse Auto	Ackley
Birdnow Auto Salvage, Inc.	Fayette	Quandt Auto Salvage, Inc	Carroll
Boyes Auto & Truck Wrecking	Dubuque	Sam's Riverside Auto & Truck Parts	Des Moines
Carroll Auto Wrecking	Des Moines	Sanborn Auto, Inc.	Sanborn
Charlie Brown Auto, Ltd.	Creston	Sandhill Auto Salvage	Tama
Chase Auto Parts Co., INC.	Waterloo	Smith Auto Parts & Sales	Fairfield
Delp Auto & treuck	Fort Dodge	Smitty's Auto Parts, Inc.	Des Moines
Don's Auto & Truck Salvage	Des Moines	Snyder's Auto Body	Clarinda
Dumont Auto Parts	Dumont	Spilman Auto Parts, INC	Bloomfield
Grab & Go Auto Salvage, LLC	Spencer	Stuber Trucks	Waterloo
Hawkeye Auto Salvage, Inc.	De Soto	Sun Line Inc.	Cedar Rapids
High Country Auto	Cherokee	Sunset Beach Auto Salvage	Des Moines
Hogeland Auto Plaza & Salvage	Marshalltown	Swift Auto Parts	Des Moines
Hulett & Son Auto Salvage	Creston	Trail's End Auto & Truck Salvage	Des Moines
Hurst Salvage	Spencer	Van Gorp Used Cars, Inc.	Oskaloosa
JBS Auto Parts, Inc.	Britt	Van Horn Auto Parts. Inc.	Mason City
Jeff Smid Auto, Inc.	Davenport	Vander Haag's, Inc.	Council Bluffs
Jeff Smid Auto, Inc.	Iowa Falls	Vander Haag's, Inc.	Des Moines
Jerry Carney & Sons	Ames	Vander Haag's, Inc.	Sioux Falls
John's Auto	Aplington	Vander Haag's, INC.	Spencer
Kabele Truck & Auto Parts	Spirit Lake	Walker Auto Salvage	Waverly
King Automotive Salvage Center	Waterloo	Waterloo Auto Parts	Waterloo
K's Acres	Cedar Rapids	West Edge Auto Salvage	Independence
Lems Auto Recyclers, Inc.	Doon	Wilken & Sons Inc.	Kensett
Leon Recycling & auto Parts, LLC	Leon	Wilken & Sons Inc.	Nashua
Lyle's Auto Salvage	Oto	Wilken & Sons Inc.	Waukon
Midwest Auto Parts, Inc.	Waterloo	Wrench 'N Go	Des Moines
Monson Salvage, Inc.	Lone Rock	Yaw Auto Salvage	Des Moines
North End Auto Wrecking	Dubuque		



Iowa Automotive Recyclers Application for Membership

Company Name: _____

Contact Person & Title *(Name in directory)*: _____

Address: _____

City, State, Zip: _____

Phone: _____ Fax: _____

E-mail: _____ Web Site: _____

Iowa Recyclers License # *(If applicable)*: _____

Iowa Used Car Dealers License # *(If applicable)*: _____

Membership \$250.00

Enclosed is my IAR annual membership check:

- Direct Member (Iowa business which dismantles and sell used automotive parts)
- Out-of-state trading partner (dismantle and sell used automotive parts)
- Rebuilder / Collision Repair Shop and/or Automotive Service Center
- Vendor of goods and services to automotive recyclers

Membership subject to approval of IAR Board.

Signature: _____

**Please return this form with your membership check to:
Iowa Automotive Recyclers, 2214 Regal Avenue, Waterloo, Iowa 50702**

Iowa Automotive Recyclers Code of Ethics

1. To promote goodwill by maintaining fair business practices and the very highest standards possible in the sale of all parts.
2. To sell high quality parts, recognizing a fair price structure, free of deceptive practices and misrepresentations.
3. To work towards customer satisfaction through parts guarantees whenever possible and when necessary, make reasonable adjustments.
4. To give courteous and fair treatment to all customers, answer all questions and make every effort to satisfy any reasonable complaint.
5. To cooperate with law enforcement authorities to help curb theft of both autos and parts.
6. To make every effort to work towards clean and orderly working conditions and attractive business locations.
7. To advertise our products honestly, avoiding false, misleading and deceptive statements, in order to maintain goodwill and good faith in our industry.
8. To make every effort for customers in finding the parts they need through parts locating services.
9. To support the policies and regulations of the Iowa Automotive Recyclers, and to abide by the standard trade practices of the Automotive Recyclers Association.



BEHR

MASON CITY

12050 West State St.
Mason City, IA
P 641.424.9521
F 641.424.6315

LEROY IRON & METAL

A DIVISION OF BEHR IRON & STEEL

2275 Dale Ave.
LeRoy, MN 55951
P 641.329.1401
F 641.329.5801

www.JosBehr.com



**ONE OF THE MOST ADVANCED SCRAP METAL
HANDLING FACILITIES IN THE NATION.**

**PROTECTING THE
ENVIRONMENT**

FOR YOU AND OUR INDUSTRIES

SINCE 1906.

IAR Automotive Recyclers News

RJ McClellan, Inc.
445 Broadway Avenue #5
St. Paul Park, MN 55071

Change Service Requested

PRESORTED
STANDARD
U.S. POSTAGE
PAID
Twin Cities, MN
Permit No. 7911

ALJON MFG

KEEPING IT SIMPLE BUILDING IT STRONG

580CZ CAR LOGGER

New Heavier Crane

...NOW WITH...

- Continuous Rotation
- More Lifting Capacity
- Better Cab Visibility

1-800-255-6620
www.aljon.com

